

G15-10SM01-40



Micro Switch Ultra Subminiature Hinge Lever SPDT

Sub-miniature in size, the G15 Series snap-action switch is UL certified.

Color: Black

PRODUCT DETAILS

Feature :

- Variety actuator styles
- Through hole
- Quick connect
- UL certificate

General characteristic :

Rating	10A , 125/250V AC
Soldering temperature	260°C±5°C 5s
Electrical life	10,000 cycles
Mechanical life	100,000 cycles
Operation force	40±20gf (MAX)
Contact resistance	≤100mΩ MAX

Dimension:

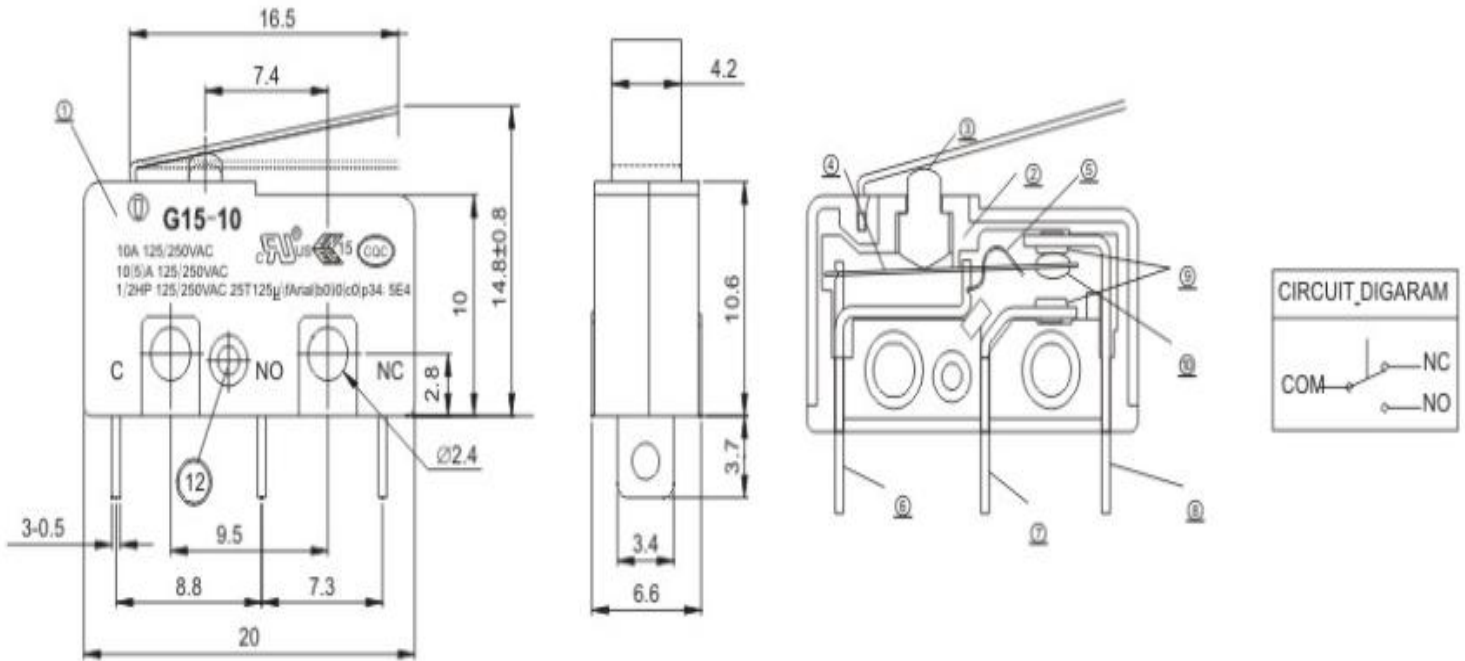

Application

❖ **Dishwasher**



❖ **Microwave Oven**



❖ **Facsimile copying machine**



Micro switch



Product: AC, Micro switch

Application: Dishwasher, Microwave Oven, DVD, LCD, CD-ROM, etc

Advantages:

- 1) self-cleaning structure of contacts;
- 2) adaptation to low speed operation;
- 3) to adapt to a variety of installation
- 4) micro gap structure and 3mm gap structure;
- 5) a variety of long-term use of the temperature range available

